

ORIGINAL LINE M

USER MANUAL



Machines with manual water filling

UM_EN

Part No.: I764022_01



| | |
|---|----|
| CONTENT | 2 |
| GENERAL | 4 |
| Introduction | 4 |
| Warnings | 4 |
| Precautions | 4 |
| Intended use | 4 |
| Facts & weight | 5 |
| General function description | 5 |
| OVERVIEW OF COMPONENTS | 6 |
| Front view | 6 |
| M-1 | 6 |
| M-2 | 7 |
| DM-4 | 8 |
| Thermos M | 9 |
| Mega Gold M | 10 |
| Thermos Office | 11 |
| INSTALLATION AND START-UP | 12 |
| Positioning | 12 |
| Electrical connection | 12 |
| Hot plate function | 13 |
| First time start-up | 13 |
| OPERATION | 15 |
| Brewing with coffee | 15 |
| To keep temperature and aroma | 17 |
| CLEANING AND CARE | 18 |
| Rinse thermos, decanter and serving station | 18 |
| Daily cleaning | 19 |
| Weekly cleaning | 19 |
| Cleaning serving station | 20 |
| Exterior cleaning | 20 |
| POSSIBLE SOLUTION | 21 |
| Fault and solution | 21 |
| DIMENSION | 22 |
| M-1 | 22 |

M-2..... 23
DM-4..... 24
Thermos M..... 25
Mega Gold M..... 26
Thermos Office..... 27

Some important information may appear in textboxes seen below

| | | | |
|---|--|------------|------------|
|  IMPORTANT! INFO. |  CAUTION! INFO. | More INFO. | Note INFO. |
|---|--|------------|------------|

Introduction

Thank you for choosing a ORIGINAL LINE coffee brewer.
We hope you enjoy it !

- Read the user guide before using the machine.
- This guide contains important instructions for proper and safe use of the vending machine.
- Always keep this guide close at hand for future reference.

Warnings

- Never immerse the machine, plug or mains cable in water because there is a danger of electric shock.
- The appliance is not intended for use by persons (including children) with reduced physical, sensory or mental capabilities, or lack of experience and knowledge, unless they have been given supervision or instruction concerning the use of the appliance by a person responsible for their safety.
- Children should be supervised to ensure they do not play with the appliance.
- Do not use the machine if the machine mains cable, plug is damaged or the machine has fallen down.
- If the mains cable is damaged, it must be replaced by the manufacturer, its service agent or similarly qualified persons in order to avoid a hazard.
- Only plug the machine into a properly installed, earthed safety socket, whose line voltage matches the technical data for the machine.
- The device must not be used with a timer switch or a separate remote control system.

Precautions

- Do not use the machine outdoors so it can be exposed to weather (rain, snow, frost). It will cause material damage to the machine.
- Do not try to open the machine or repair it in any way. To avoid danger, only have the machine repaired in a technical workshop, in the Service Centre or by a qualified person.
- Remove the mains cable from the socket, when the machine is not in use for longer periods. To do this, pull the plug, not the cable.
- This appliance must be placed in a horizontal position which is resistant to any water that may leak.
- Place the machine out of the reach of children.
- Position the mains cable so that people cannot trip over it. Keep it away from sharp edges and heat sources.
- This appliance must not be cleaned by a water jet.

Intended use

- This appliance is intended to be used in household and similar applications such as:
 - Staff kitchen areas in shops.
 - Offices and other commercial working environments.
 - On agricultural estates.
 - By clients in hotels, motels and other residential type environments.
 - Bed and breakfast type environments.
- For the optimal performance of the machine these parameters shall not be exceeded:
 - Maximum working temperature: 40 °C
 - Minimum working temperature: 10 °C

Facts & weight

| FACTS | M-1 | M-2 | Office Thermos | DM-4 | Thermos M | Mega Gold M |
|-------------------------------------|-----------------------------------|-----------------------------------|-----------------------------------|--------------------|-----------------------------------|------------------|
| Height, Width, Depth | 428, 205, 410 mm | | | 428, 410, 410 mm | 557, 205, 410 mm | 655, 205, 445 mm |
| Thermos/de-canter volume | 1.8 L | 1.8 L | 1.9 L | 2x1.8 L | 2.2 L | 2.5 L |
| Power supply | 220-230V IN ~ 2295W 50-60Hz | 220-230V IN ~ 2390W 50-60Hz | 220-230V IN ~ 2200W 50-60Hz | 400V 2N~ 4780 W | 220-230V IN ~ 2200W 50-60Hz | |
| Max number of cups each brew | 12 Cups | 12 Cups | 12 Cups | 2x12 Cups | 15 Cups | 17 Cups |
| Capacity | 15 L/h | 15 L/h | 15 L/h | 30 L/h | 15 L/h | 19 L/h |
| Brew time | 6min | 6min | 6min | 6min | 7min | 8.5min |
| Hot plates | 1 | 2 | None | 4 | None | None |

| MODEL/NAME | M-1 | M-2 | Office Thermos | DM-4 | Thermos M | Mega Gold M |
|---------------|------|------|----------------|---------|-----------|-------------|
| Weight | 8 kg | 9 kg | 9.5 kg | 15.5 kg | 10 kg | 11.5 kg |

General function description

- The water tank is fitted with a float switch that will activate heating unit when water is filled, this starts the brew process. During the brewing process a lamp will be lit on the machine's right side. When the tank is empty of water the heater unit will be switched off and the lamp will be turned off.
- A brew process takes around 6-8.5minutes to complete.

Front view

M-1

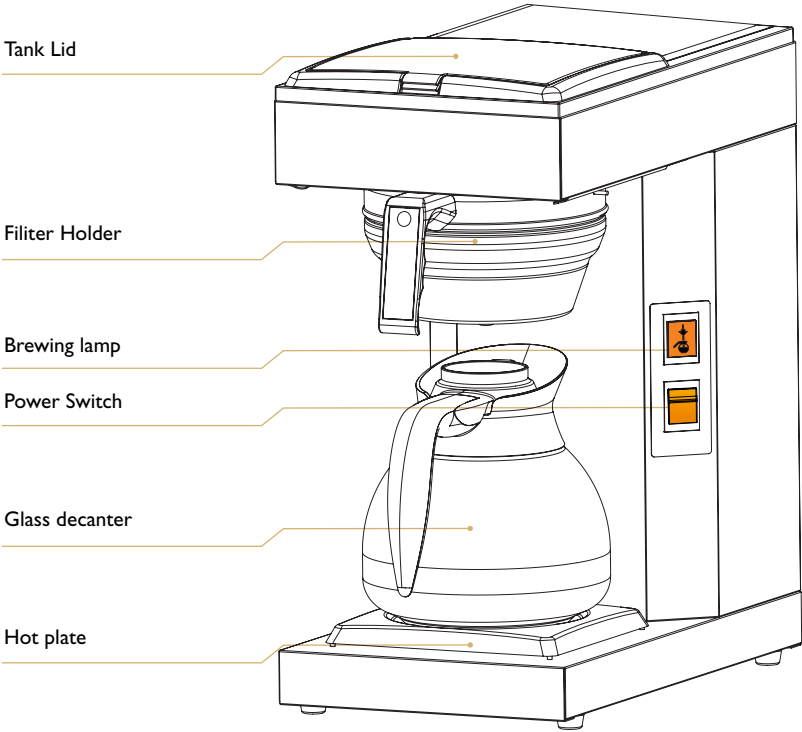

Front view

M-2

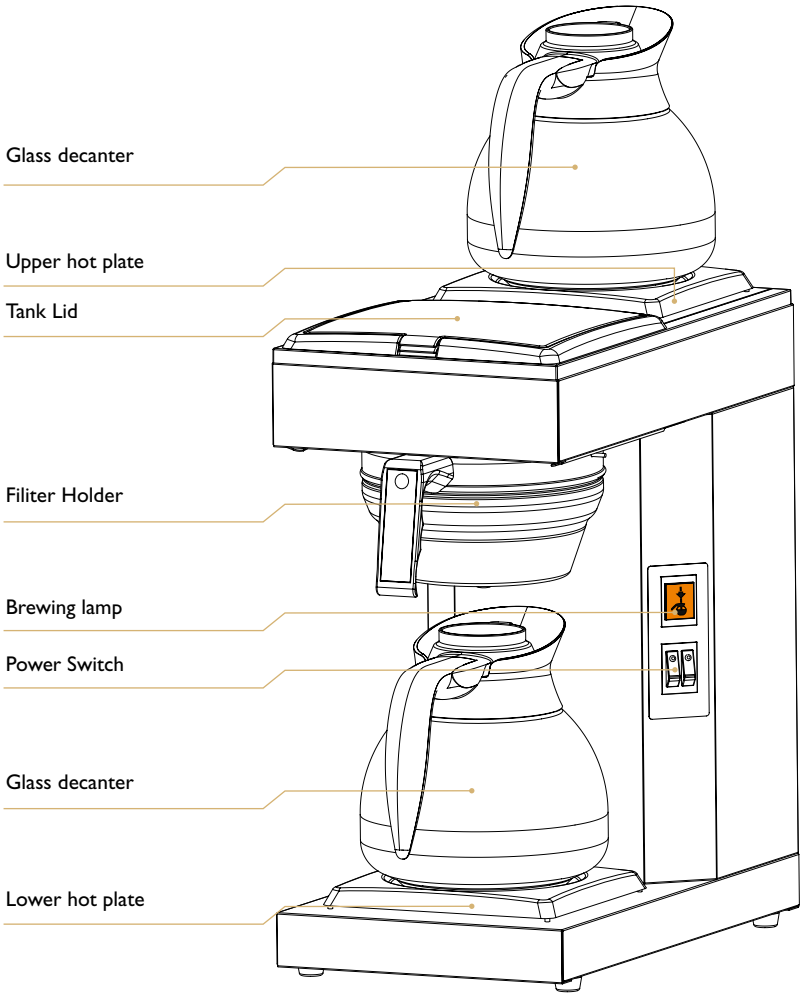

Front view

DM-4

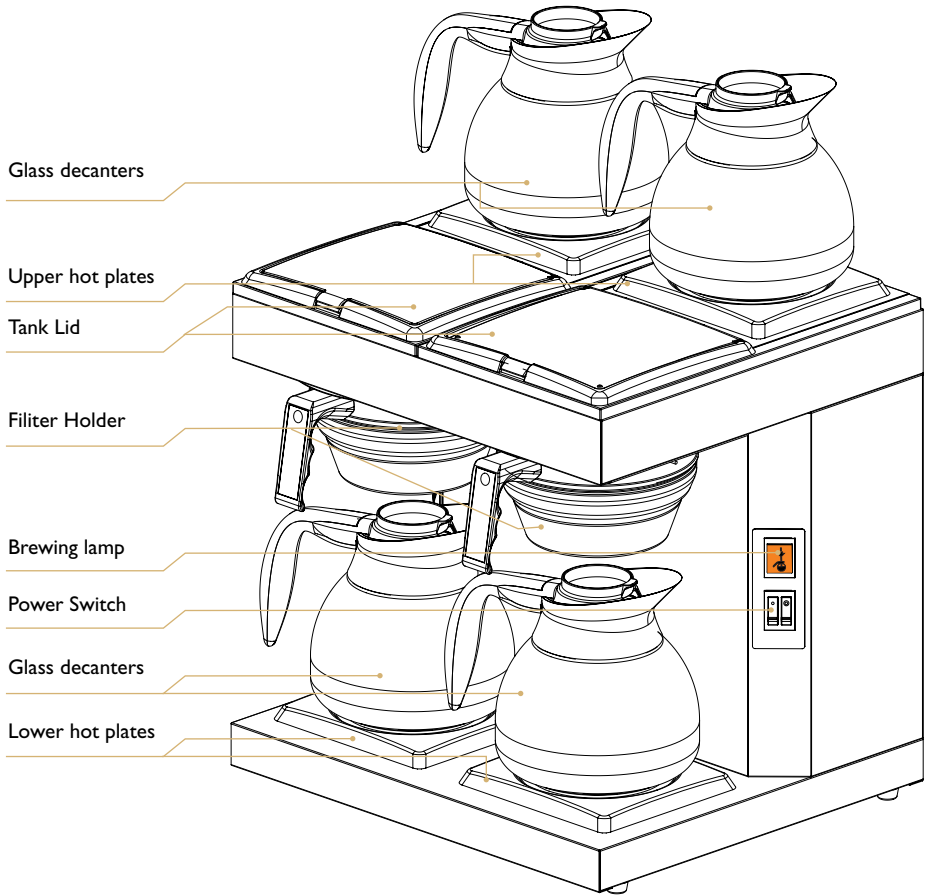

Front view

Thermos M

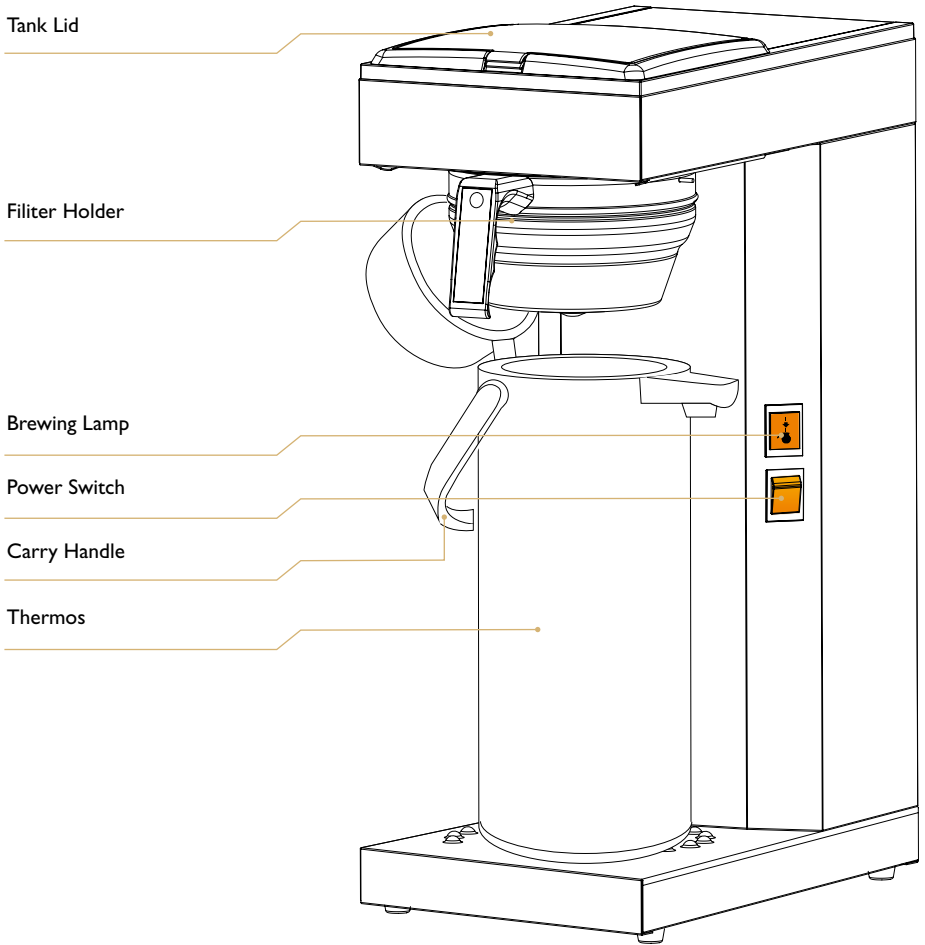

Front view

Mega Gold M

Tank Lid

Filiter Holder

Brewing Lamp

Carry Handle

Power Switch

Serving Station

Tap for Coffee

Drip Tray Insert

Drip Tray

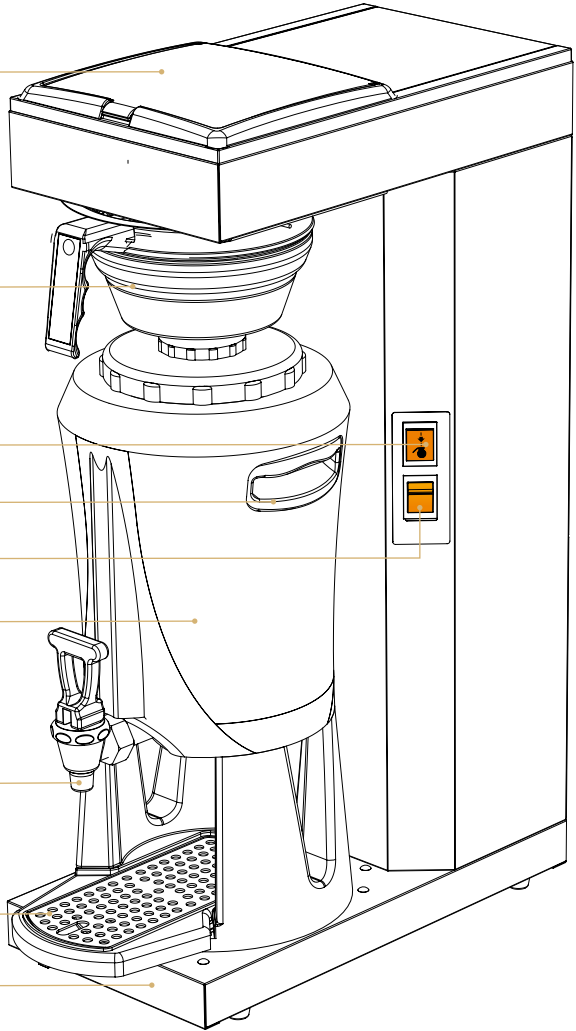

Front view

Thermos Office

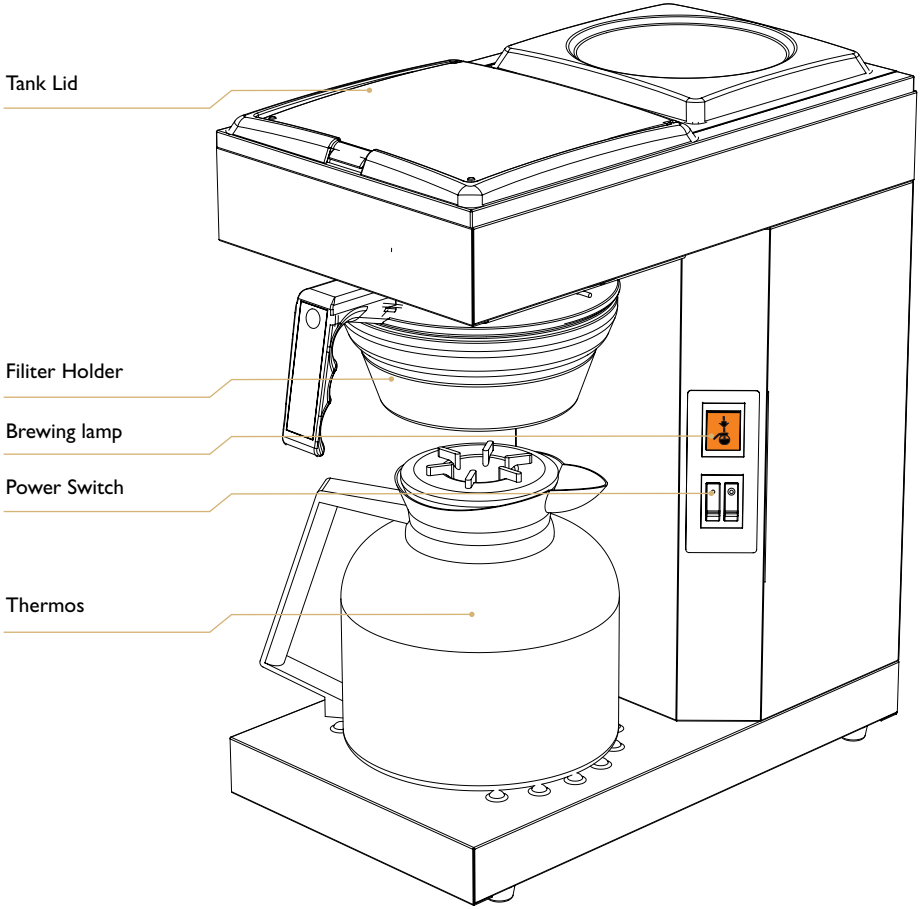

Positioning

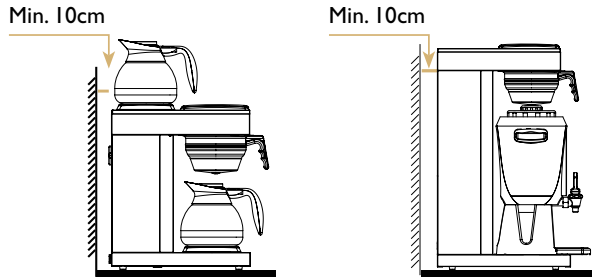

- Place the machine on a flat horizontal surface that will support the weight of the machine.

Note Make sure air is able to circulate behind the machine (minimum 10cm).

Electrical connection

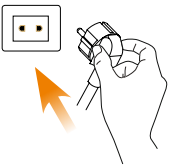

M-1, M-2, THERMOS M, MEGA GOLD M

- **IMPORTANT!**
Connect the plug to a separate earthed wall socket.
220-230 V 50-60Hz, 10 Amp.

DM-4

- The brewer is not reconnectable and may only be installed to the electric supply network with a voltage that is stated on the brewer and shall be carried out by an authorized electrician.
- Recommended: install a line circuit breaker and a earth fault breaker to the machine.
- **CAUTION!**
Connection to a separate 2 phase only
- Brewer should be connected to 400V with zero and earth.
- Use 10 Amp fuses.
- **IMPORTANT!**
Electrical installations must be done of an certificated electrician: 400V 2N~4780 W

Hot plate function

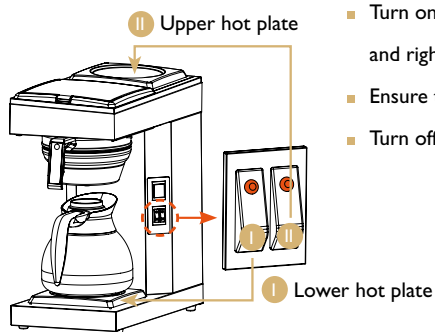

- Turn on left power switch: **I** for lower hot plate, and right power switch: **II** for upper hot plate.
- Ensure that the lamps turn on and that the hot plates get warm.
- Turn off power switches **I** and **II** when not in use.

First time start-up

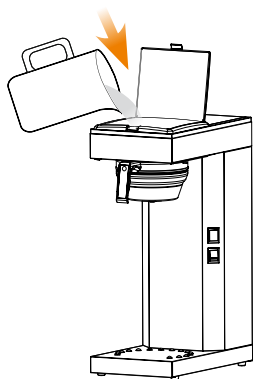

IMPORTANT!

First time you use the machine do the first brewing with water only.

- Slide the filter holder into position without filter and coffee.
- Lift up the tank lid and fill the machine with 1.8L fresh tap water.

Do not fill it under running water (e.g. a tap). Only use the decanter.



WARNING

- Do not overfill, it is recommended that you always use the decanter supplied with the machine to measure the water quantity.
- Never fill the machine with brewed coffee, this may result in material damage.

First time start-up

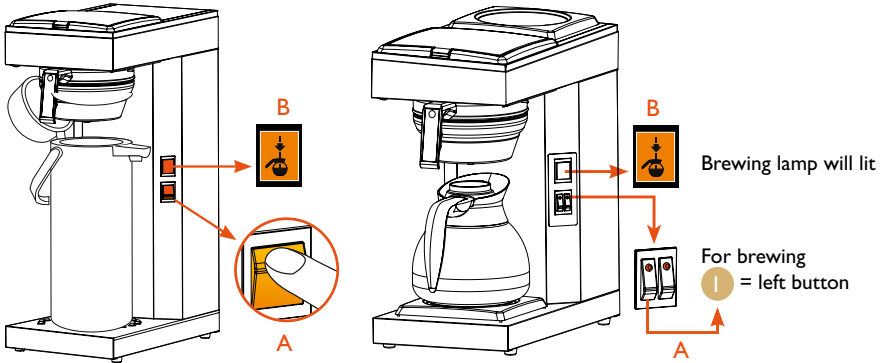

IMPORTANT!

A thermos or decanter must always be in the machine when brewing is in progress.

- Place the thermos or decanter under the filterholder.
- Wait two minutes to let the system air-out and fill the heater unit.
- Turn on the power switch.(A)
- The brew lamp (B) will now be lit and indicates that brewing is in progress.
- After 20-30 seconds water shall start to pour into the filterholder and down in the thermos or decanter.
- When brewing is completed, empty the thermos or decanter.
- A whole brew process takes around 6~8 minutes.

Brewing with coffee

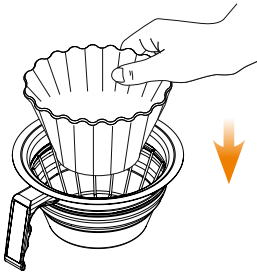

- Place a 90mm filter in the filter holder.

01



Recommended
powder amount is
60g/L

- Add coffee (restaurant / catering ground coffee). Make sure that the coffee is evenly spread.

02

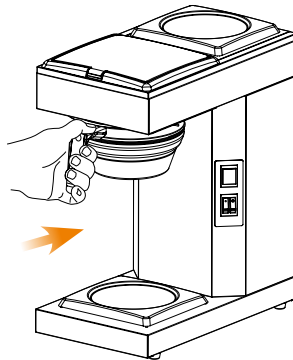
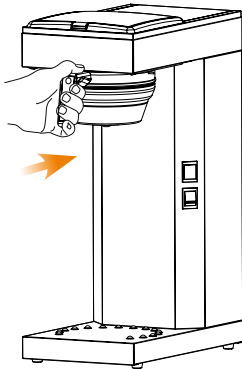

- Slide the filter holder into position.

03

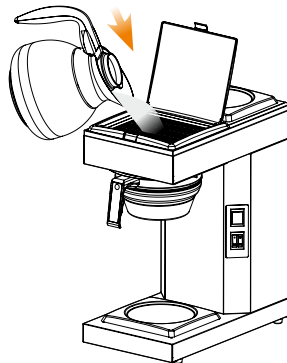
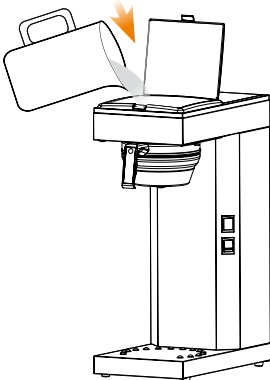

- Lift up the tank lid and pour in a decanter of fresh tap water.

04

Brewing with coffee

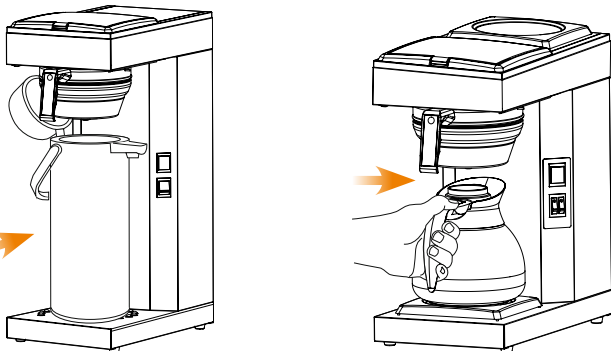

- Place the thermos or decanter under the filterholder.

05

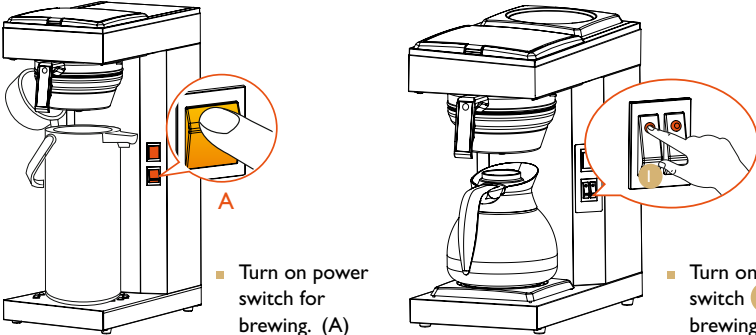

- Turn on power switch for brewing. (A)
- Turn on power switch I for brewing.

06

Tips
Do not mix freshly brewed coffee with old coffee kept warm. It will result in poor coffee quality.

CAUTION!
Under no circumstances fill brewed coffee or coffee powder into the water tank. It may cause machine damage.



- During the brewing, (about 6 minutes) the brew lamp is lit.

07

To keep temperature and aroma

Tips for keeping coffee hot

Pre-heat the serving station, start a brewing with only water into the serving station. When brewing is complete let it stand for about 1 hour. Pour out the water. Then start a brew with coffee.

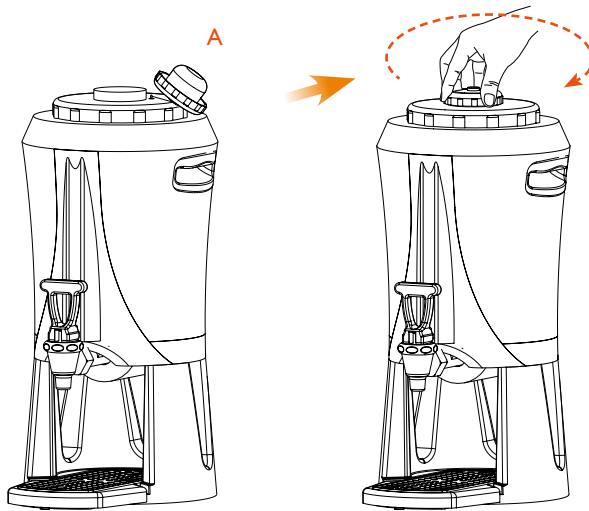

- To keep temperature and aroma, put the lid (A) back on the serving station immediately after the brewing.



IMPORTANT!

- The temperature in the serving station will decrease with $\sim 1.5^{\circ}\text{C}/\text{h}$. There is $\sim 30\text{ml}$ of coffee standing in the tubes from the inner container to the coffee faucet. This part is not insulated and will drop in temperature much faster. If the serving station haven't been used in 1h the first cup can be lower in temperature. Cups after the first will not be affected of this.

Tips for achieving the best quality

- Do not change the recommended portion of coffee.
- Do not mix freshly brewed coffee with old coffee.
- Always rinse the serving station before next brew.
- Empty the filter holder from filter and coffee grounds directly after a brew.
- Dispense 50ml of coffee every hour to always have fresh and hot coffee to the faucet.

Rinse thermos, decanter and serving station

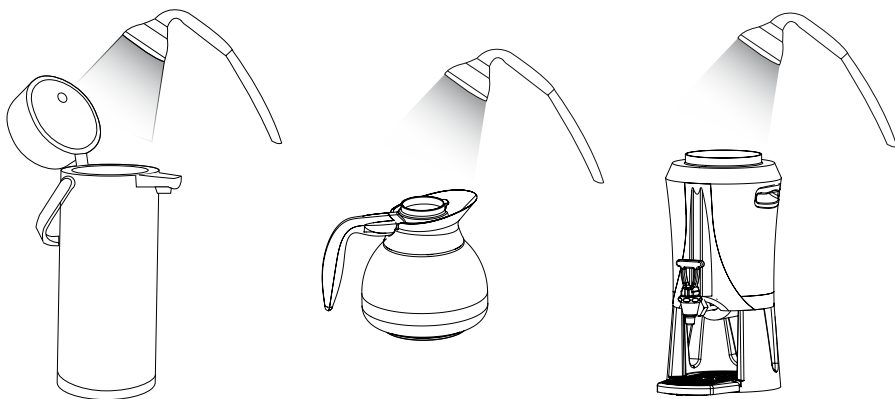

- Before each brewing, rinse the thermos, decanter or serving station with fresh tap water.
- When cleaning the outside, use a soft rag with liquid cleaning agent to prevent scratches.

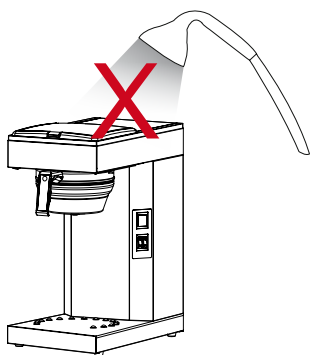
 **CAUTION!**

The machine should not be submerged in water or washed in a dishwasher: it will result in machine damage.

Dayly cleaning

- Wash the thermos, decanter(B) and the filter holder with liquid solution for coffee machines. Always remove the filter immediately and clean the filter holder daily, coffee will get moldy.
- Clean the spray nozzle(A) and the surrounding area.
- Use a soft rag and liquid solution that does not scratch.

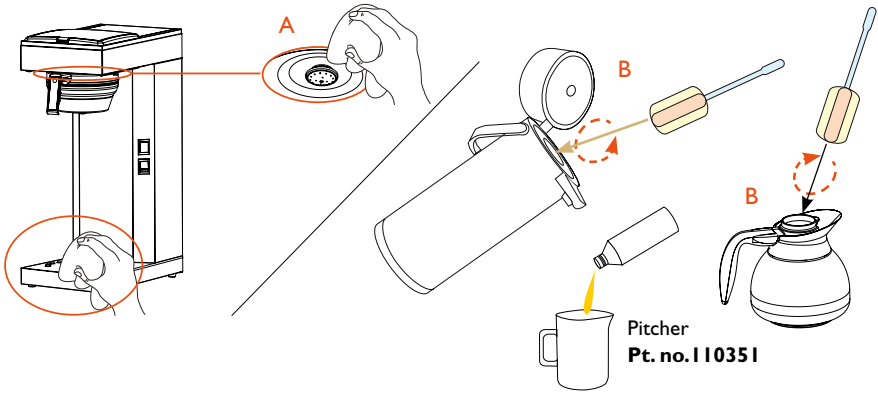

Weekly cleaning

- Descaling and cleaning.
- Pour 50 ml descaling / cleaning solution in a decanter and fill it up with cold water.
- Pour the mixture in the machine and proceed with a brewing without a filterpaper or coffee.
- Rinse the machine thoroughly by brewing at least 3 times with clean water so that the particles from descaling solution disappear.
- Regular descaling will ensure optimum brewing performance and a longer life of the machine.
- When cleaning the decanter in a dishwasher: Dismantle lid and place decanter upside down in the dishwasher: (A)



Cleaning serving station

- Disassemble the level tube and clean it every week with the enclosed brush.
- Take off the main lid and clean the mixer tube(A).

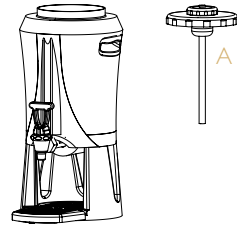

IMPORTANT!

Rinse the inside of the serving station several times with fresh tap water.

Cleaning of serving station 2.5 L

- Fill the serving station with hot water. (Full brewing without coffee and filter).
- Put 1 tablespoon with cleaning powder in the serving station and wait at least 15 minutes.
- Tap out 2/3 of the cleaning solution.
- Clean the serving station with the cleaning brush.
- Rinse the serving station with fresh tap water several times before reuse.



OPTIONS



| Part No. | CLEANING PARTS |
|------------|---|
| I 10102-02 | Cleaning powder |
| I 104231 | Cleaning brush |
| I 103360 | Cleaning brush for level tube, mixer tube |

Exterior cleaning

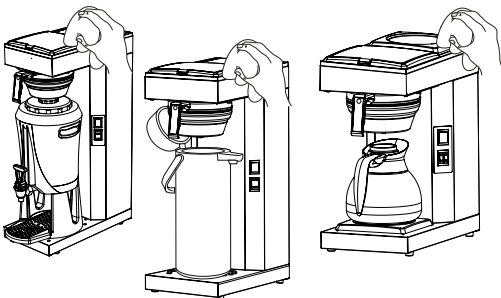

- When cleaning exterior of the machine, use a soft rag with liquid cleaning agent to prevent scratches.

Fault and solution



IMPORTANT!

All maintenance and installations must be done of an authorized technician.

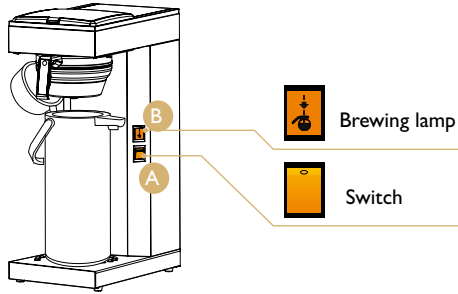

| FAULT | POSSIBLE SOLUTION |
|---|---|
| Power switch A does not light | <ul style="list-style-type: none"> ■ Check plug connection to wall socket. ■ Check fuse in plug. |
| Brewer omits excess steam | <ul style="list-style-type: none"> ■ Machine may require descaling. ■ Spray nozzle may need unblocking. ■ Hose may be bent. ■ Inlet to boiler may be blocked. Descal machine - if boiler still defective - replace. |
| Brewing lamp B does not light, machine will not brew | <ul style="list-style-type: none"> ■ Overheating-switch has activated - reset with button. ■ Check microswitch. ■ Check float. |
| Brewing lamp B is lit but machine will not brew | <ul style="list-style-type: none"> ■ Check connection to boiler. ■ Boiler unit may need replacing. |

M-I

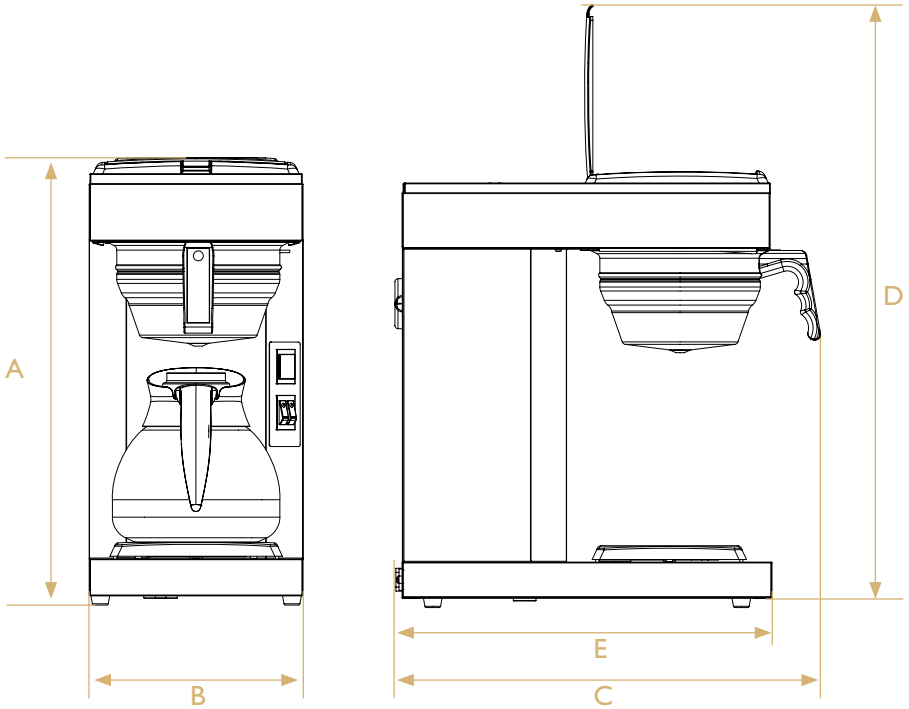

| Model | A | B | C | D | E |
|-------|-------|-------|-------|-------|-------|
| M-I | 428mm | 205mm | 410mm | 578mm | 360mm |

M-2

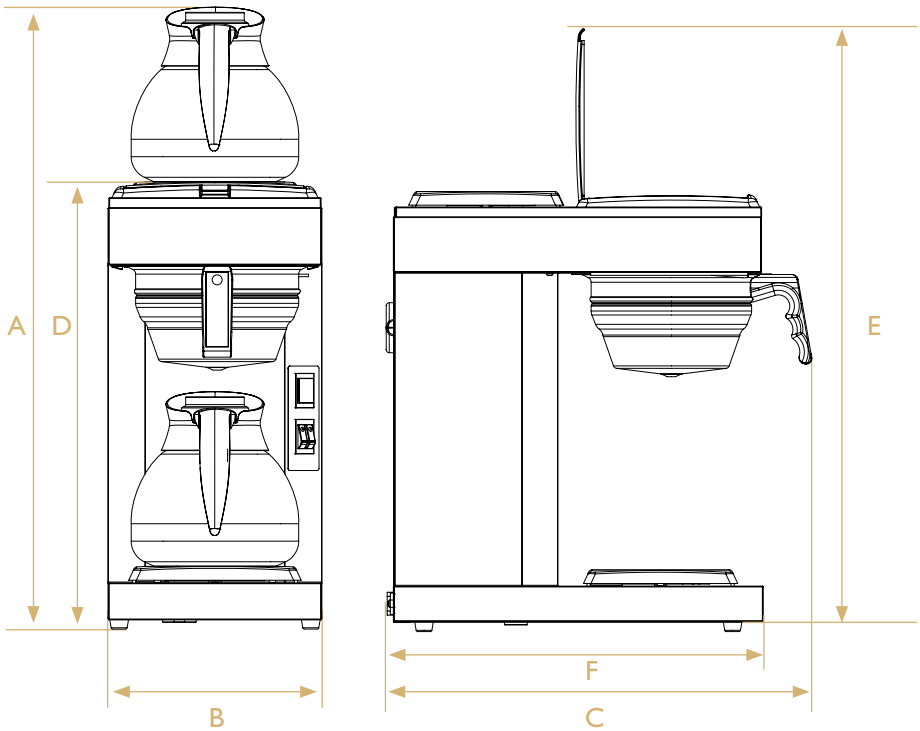

| Model | A | B | C | D | E | F |
|-------|-------|-------|-------|-------|-------|-------|
| M-2 | 595mm | 205mm | 410mm | 428mm | 578mm | 360mm |

DM-4

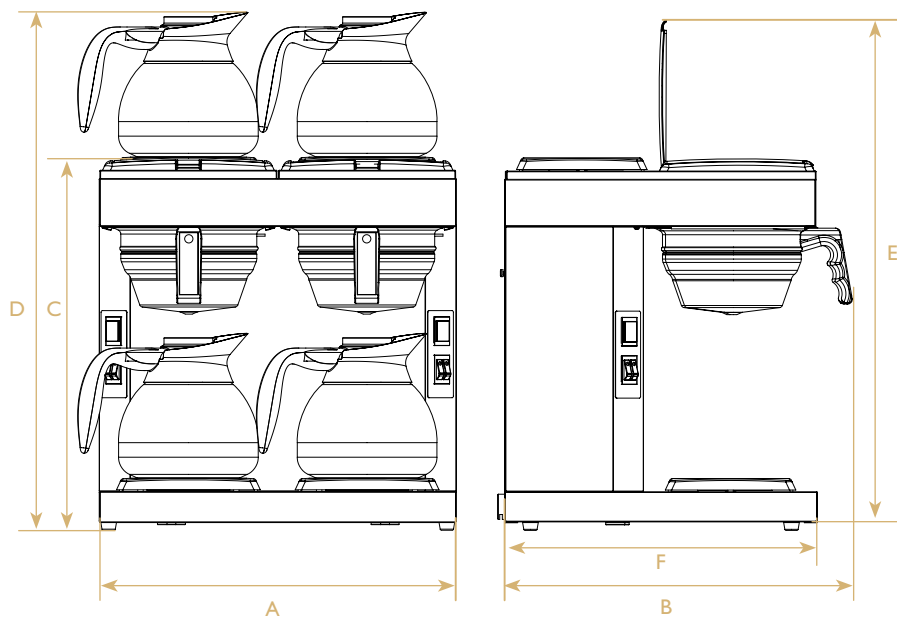

| Model | A | B | C | D | E | F |
|-------------|-------|-------|-------|-------|-------|-------|
| DM-4 | 410mm | 410mm | 428mm | 595mm | 578mm | 360mm |

Thermos M

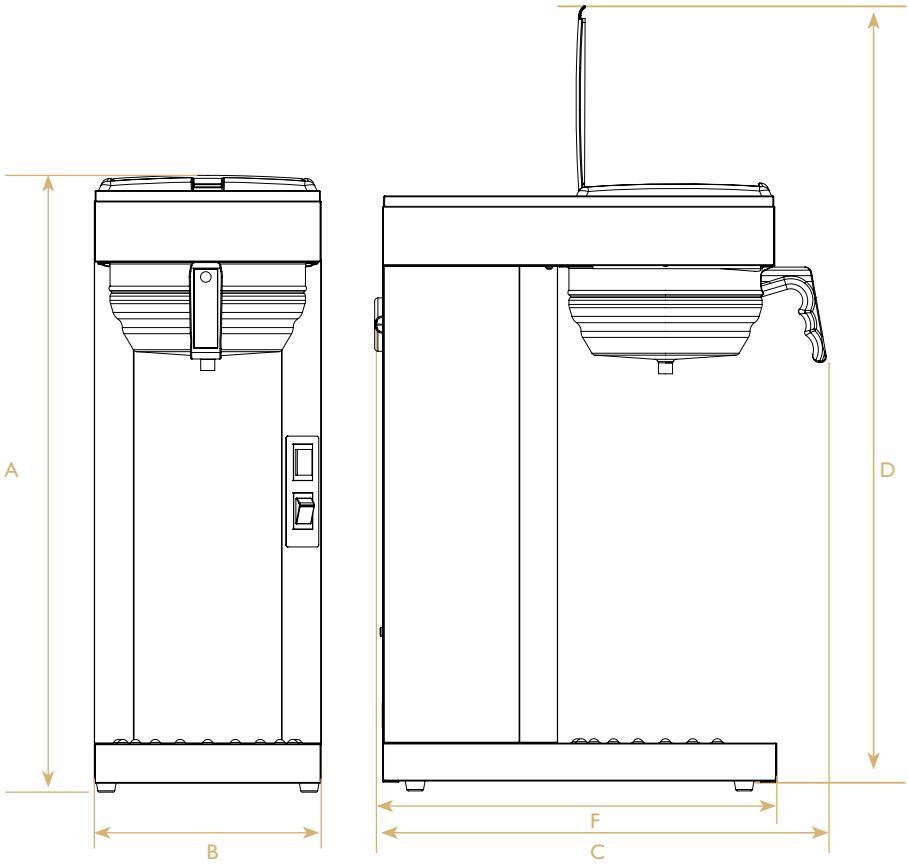

| Model | A | B | C | D | F |
|------------------|-------|-------|-------|-------|-------|
| Thermos M | 557mm | 205mm | 410mm | 708mm | 360mm |

Mega Gold M

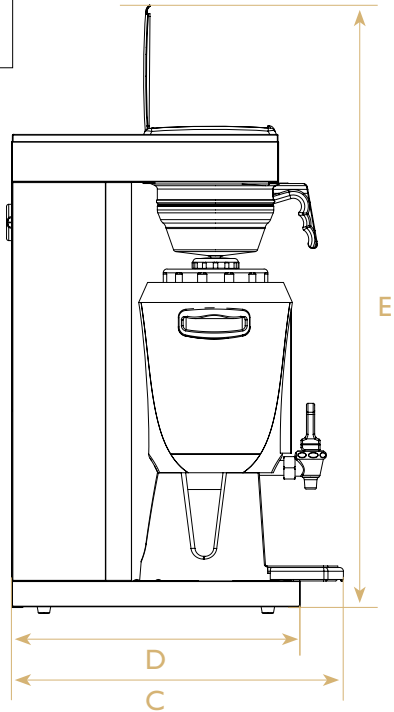
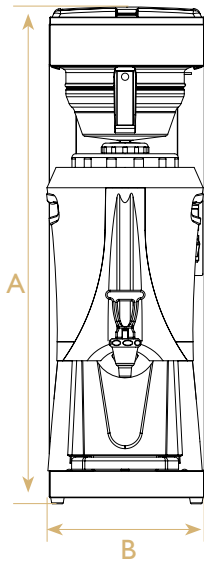
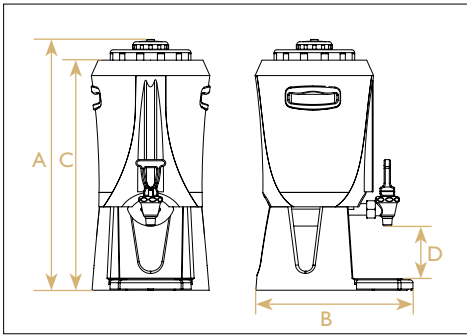

| Model | A | B | C | D | E |
|------------------------|-------|-------|-------|-------|-------|
| Mega Gold M | 655mm | 205mm | 445mm | 390mm | 806mm |
| Serving Station | 436mm | 273mm | 400mm | 105mm | |

Thermos Office

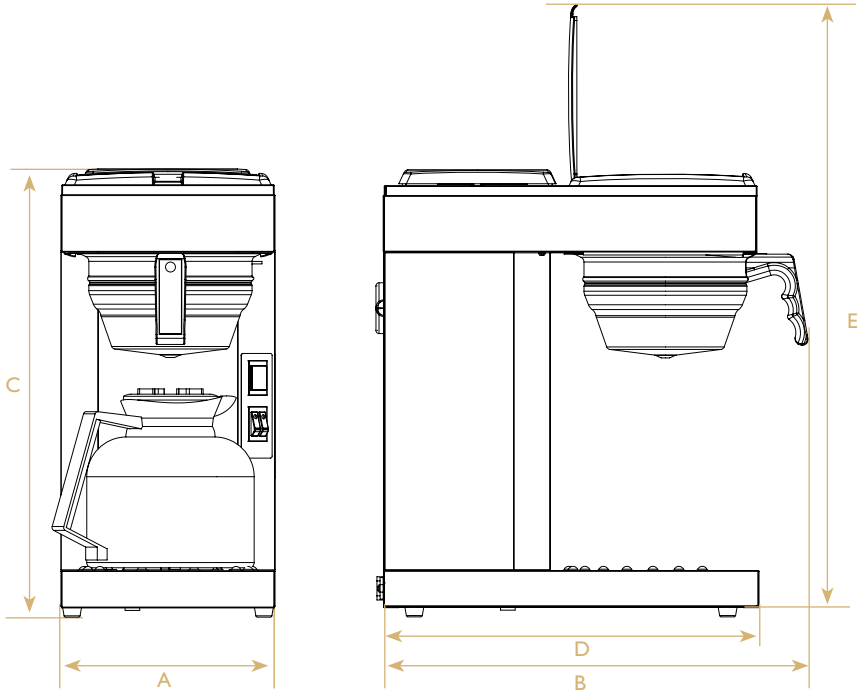

| Model | A | B | C | D | E |
|-----------------------|-------|-------|-------|-------|-------|
| Thermos Office | 205mm | 410mm | 428mm | 360mm | 578mm |

For the warranty to be valid the conditions for maintenance must have been followed according to our instructions, proper precaution has been made and warranty claim been issued without delay.

The affected equipment may not be used during awaiting service if there is any risk that the damage or defect would worsen.

The warranty will not cover consumption supplies such as glassware, normal maintenance such as cleaning of filters, contaminations in water, lime, incorrect voltages, pressure or adjustment of water amounts.

The warranty will not cover damages of defects caused by incorrect handling and operation of the appliance.

FOR SERVICE

Please contact your dealer

Your Dealer

