



mod. 150
STANDARD



mod. 150
COLOURS

Isola panoramica a Refrigerazione Ventilata (RV).

Disponibile in due diverse temperature:

TN per l' esposizione di prodotti freschi confezionati

TN FV per l' esposizione di frutta e verdura fresca e/o confezionata

Panoramic island-site case, at Ventilated Refrigeration (RV).

Available in two different temperatures:

TN for the display fresh pre-packed products

TN FV for the display of vegetables and fruits and/or pre-packed

COMPRESA UNITA' CONDENSATRICE A BORDO	
CONDENSING UNIT INCLUDED	
ARIA AIR	ARIA AIR
STANDARD	COLOURS

MODELLO MODEL	CODICE CODE
150 RV TN	KOR0150S00L
200 RV TN	KOR0200S00L
250 RV TN	KOR0250S00L
150 RV TN FV	KOR0150S01L
200 RV TN FV	KOR0200S01L

INCLUSO: - IMBALLO
INCLUSIVE OF: - PACKAGING

● Dotazioni di serie Standard equipment

- Kit griglie fondovasca Base grid

Profilo (COLOURS): Colori disponibili standard

Bumper (COLOURS): Available standard colours



Rosso Rubino Ruby	Verde Pino Pine	Blu Zaffiro Saphire	Turchese Turquoise	Giallo Cedro Cedar
-------------------------	-----------------------	---------------------------	-----------------------	--------------------------

OPTIONAL

		Modello Model	Codice Code
● Divisorio (nr. 1)	Divider (nr. 1)		9003990102700
● Kit sponde	Kit panoramic side panels	150	9003990102900
		200	9003990102910
		250	9003990102920
● Kit divisori 10 scomparti	Kit dividers 10 compartments	150	9003990204900
● Kit divisori 27 scomparti	Kit dividers 27 compartments	150	9003990205000
● Kit divisori 14 scomparti	Kit dividers 14 compartments	200	9003990205101
● Kit divisori 33 scomparti	Kit dividers 33 compartments	200	9003990105101
● Kit divisori 18 scomparti	Kit dividers 18 compartments	250	9003990205200
● Kit divisori 39 scomparti	Kit dividers 39 compartments	250	9003990205300

Aree personalizzabili Customizable area

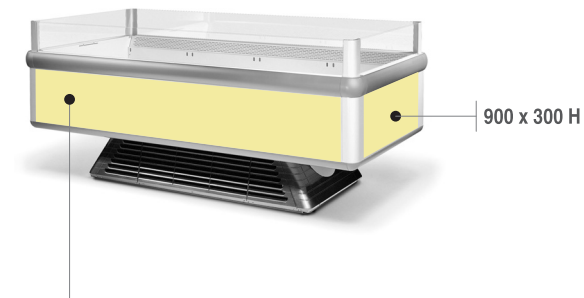

mod. **150** - 1360 x 300 H
 mod. **200** - 1860 x 300 H
 mod. **250** - 2360 x 300 H

Caratteristiche Tecniche	Technical features	150		200		250
		TN	TN FV	TN	TN FV	TN
Dimensioni esterne (lpxh)	External dimensions (lxdxh)	1540 x 1040 x 895		2040 x 1040 x 895		2540 x 1040 x 895
Refrigerazione	Refrigeration	Ventilata Ventilated		Ventilata Ventilated		Ventilata Ventilated
Capacità' (lorda-netta)	Capacity (gross - net)	548 / 261		743 / 354		938 / 445
Temperatura prodotto	Product temperature	-1 / +7		-1 / +7		-1 / +7
		+1 / +10		+1 / +10		
Sbrinamento	Defrost	Elettrico Electrical	Fermata Compressore Off Cycle	Elettrico Electrical	Fermata Compressore Off Cycle	Elettrico Electrical
Classe climatica	Climatic class	3		3		3
Condizioni ambientali	Operating conditions	25 / 60		25 / 60		25 / 60
Compressore (Tipo - n°)	Compressor (type - n°)	Ermetico Hermetic (1)		Ermetico Hermetic (1)		Ermetico Hermetic (1)
Alimentazione	Power supply	230 / 1 / 50		230 / 1 / 50		230 / 1 / 50
Assorbimento elettrico (regime)	Electrical input (standard)	1000 / 5.2	420 / 2.7	1290 / 6.7	550 / 3.5	1400 / 6.5
Assorbimento elettrico (sbrinamento)	Electrical input (defrost)	1100 / 4.7	20 / 0.1	1400 / 6	20 / 0.1	1700 / 7.4
Peso netto	Net weight	115		163		188

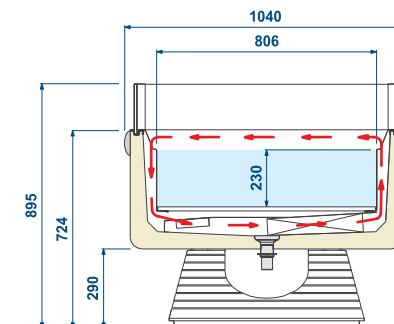

Modelli con unità condensatrici a bordo (condensazione ad aria)
 Models with condensing unit included (air cooled)

Isola panoramica a **Refrigerazione Ventilata (RV)**, per l'esposizione di gelati, surgelati e/o prodotti freschi confezionati.

Panoramic island-site case, at **Ventilated Refrigeration (RV)**, for display ice-cream, frozen food and/or fresh pre-packed products.

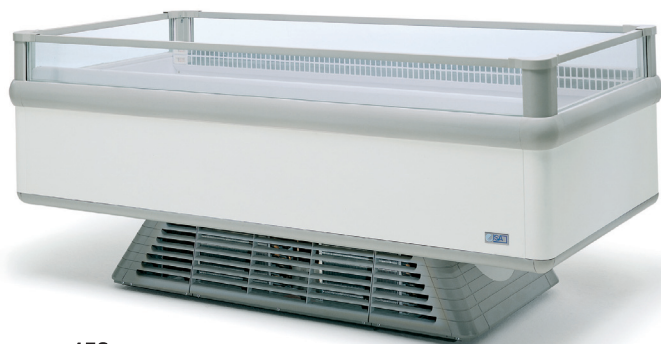

mod. **150**
STANDARD



mod. **150**
COLOURS

COMPRESA UNITA' CONDENSATRICE A BORDO	
CONDENSING UNIT INCLUDED	
ARIA AIR	ARIA AIR
STANDARD	COLOURS

MODELLO MODEL	CODICE CODE
150 RV TB	ECN0150S00L
200 RV TB	ECN0200S00L
250 RV TB	ECN0250S00L
150 RV TB/TN	ECN0150S00L
200 RV TB/TN	ECN0200S00L
250 RV TB/TN	ECN0250S00L

INCLUSO: - IMBALLO
INCLUSIVE OF: - PACKAGING

● **Dotazioni di serie** Standard equipment

- Kit griglie fondovasca (TB/TN) Base grid (TB/TN)

Profilo (COLOURS): Colori disponibili standard

Bumper (COLOURS): Available standard colours



Rosso Rubino Ruby	Verde Pino Pine	Blu Zaffiro Sapphire	Turchese Turquoise	Giallo Cedro Cedar
-------------------------	-----------------------	----------------------------	-----------------------	--------------------------

OPTIONAL

		Modello Model	Codice Code
● Divisorio (nr. 1)	Divider (nr. 1)		9003990102700
● Kit coperchi notte coibentati	Insulated night covers	150	9003990105400
		200	9003990105500
		250	9003990105600
● Scorrevoli	Sliding lids	150	9003990206600
		200	9003990206700
		250	9003990206800
● Kit divisori 10 scomparti	Kit dividers 10 compartments	150	9003990204900
● Kit divisori 27 scomparti	Kit dividers 27 compartments	150	9003990205000
● Kit divisori 14 scomparti	Kit dividers 14 compartments	200	9003990205101
● Kit divisori 33 scomparti	Kit dividers 33 compartments	200	9003990105101
● Kit divisori 18 scomparti	Kit dividers 18 compartments	250	9003990205200
● Kit divisori 39 scomparti	Kit dividers 39 compartments	250	9003990205300

Aree personalizzabili Customizable area

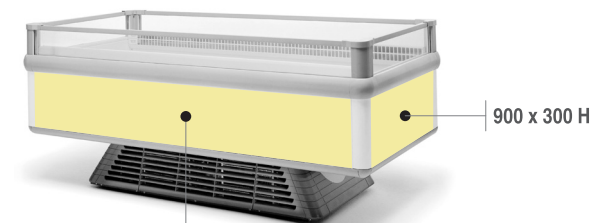

mod. **150** - 1360 x 300 H
 mod. **200** - 1860 x 300 H
 mod. **250** - 2360 x 300 H

Caratteristiche Tecniche

Technical features

			150	200	250
			TB - TB / TN	TB - TB / TN	TB - TB / TN
Dimensioni esterne (lpxh)	External dimensions (lxdxh)	mm	1540 x 1040 x 885	2040 x 1040 x 885	2540 x 1040 x 885
Refrigerazione	Refrigeration		Ventilata Ventilated	Ventilata Ventilated	Ventilata Ventilated
Capacità (lorda-netta)	Capacity (gross - net)	lt	509 / 235	691 / 399	872 / 504
Temperatura prodotto	Product temperature	°C	-18 / -15 (TB) -1 / +5 (TN)	-18 / -15 (TB) -1 / +5 (TN)	-18 / -15 (TB) -1 / +5 (TN)
Sbrinamento	Defrost		Elettrico Electrical	Elettrico Electrical	Elettrico Electrical
Classe climatica	Climatic class	N°	3	3	3
Condizioni ambientali	Operating conditions	°C / %RH	25 / 60	25 / 60	25 / 60
Compressore (Tipo - n°)	Compressor (type - n°)		Ermetico Hermetic (2)	Ermetico Hermetic (2)	Ermetico Hermetic (2)
Alimentazione	Power supply	V / ph / Hz	230 / 1 / 50	230 / 1 / 50	230 / 1 / 50
Assorbimento elettrico (regime)	Electrical input (standard)	W / A	1050 / 6.1	1150 / 6.6	1990 / 9.8
Assorbimento elettrico (sbrinamento)	Electrical input (defrost)	W / A	1600 / 7.2	2440 / 10	3410 / 14.8
Peso netto	Net weight	kg	166	194	218

Modelli con unità condensatrici a bordo (condensazione ad aria)
 Models with condensing unit included (air cooled)

1.006

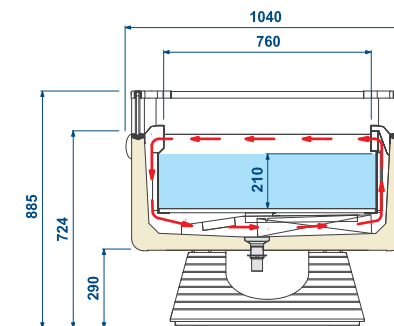

ISOLE ISLAND-SITE DISPLAY CASE

Isola panoramica a **Refrigerazione Statica (RS)**, per l'esposizione di gelati e surgelati.

Panoramic island-site case, at **Static Refrigeration (RS)**, for display of ice-cream and frozen food.



mod. **150**
STANDARD



mod. **150**
COLOURS

COMPRESA	
UNITA' CONDENSATRICE A BORDO	
CONDENSING UNIT INCLUDED	
ARIA AIR	ARIA AIR
STANDARD	COLOURS

MODELLO MODEL	CODICE CODE
150 RS TB	ECP0150S00L
200 RS TB	ECP0200S00L
250 RS TB	ECP0250S00L

INCLUSO: - IMBALLO
INCLUSIVE OF: - PACKAGING

Profilo (COLOURS): Colori disponibili standard

Bumper (COLOURS): Available standard colours

Rosso Rubino Ruby	Verde Pino Pine	Blu Zaffiro Saphire	Turchese Turquoise	Giallo Cedro Cedar

● OPTIONAL		Modello Model	Codice Code
● Divisorio (nr. 1)	Divider (nr. 1)		9003990101900
● Kit coperchi ABS	ABS covers	150	9003990102000
		200	9003990102100
		250	9003990102200
● Kit coperchi notte coibentati	Insulated night covers	150	9003990102300
		200	9003990102400
		250	9003990102500
● Scorrevoli	Sliding lids	150	9003990112500
		200	9003990112600
		250	9003990112700
● Kit divisori 10 scomparti	Kit dividers 10 compartments	150	9003990206000
● Kit divisori 27 scomparti	Kit dividers 27 compartments	150	9003990206100
● Kit divisori 14 scomparti	Kit dividers 14 compartments	200	9003990206200
● Kit divisori 33 scomparti	Kit dividers 33 compartments	200	9003990206300
● Kit divisori 18 scomparti	Kit dividers 18 compartments	250	9003990206400
● Kit divisori 39 scomparti	Kit dividers 39 compartments	250	9003990206500

■ Aree personalizzabili Customizable area

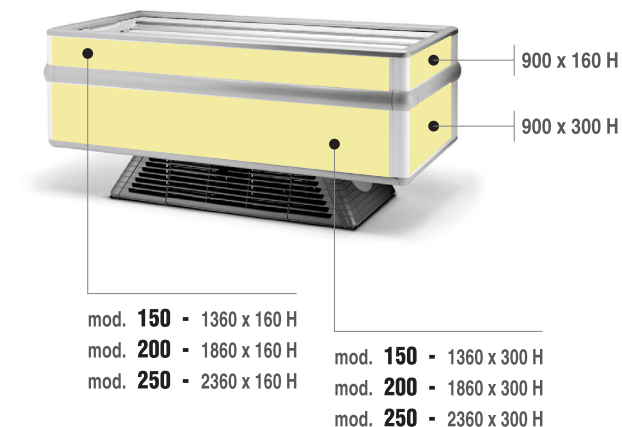

Caratteristiche Tecniche	Technical features	150			200			250			
		TB			TB			TB			
Dimensioni esterne (lpxh)	External dimensions (lxdxh)	mm	1540 x 1040 x 921			2040 x 1040 x 921			2540 x 1040 x 921		
Refrigerazione	Refrigeration		Statica Static			Statica Static			Statica Static		
Capacità' (lorda-netta)	Capacity (gross - net)	lt	548 / 360			748 / 508			948 / 631		
Temperatura prodotto	Product temperature	°C	-18 / -15			-18 / -15			-18 / -15		
Sbrinamento	Defrost		Elettrico Electrical			Elettrico Electrical			Elettrico Electrical		
Classe climatica	Climatic class	N°	4			4			4		
Condizioni ambientali	Operating conditions	°C / %RH	30 / 55			30 / 55			30 / 55		
Compressore (Tipo - n°)	Compressor (type - n°)		Ermetico Hermetic (2)			Ermetico Hermetic (2)			Ermetico Hermetic (2)		
Alimentazione	Power supply	V / ph / Hz	230 / 1 / 50			230 / 1 / 50			230 / 1 / 50		
Absorbimento elettrico (regime)	Electrical input (standard)	W / A	1120 / 8.4			1380 / 9.6			1400 / 10		
Absorbimento elettrico (sbrinamento)	Electrical input (defrost)	W / A	1430 / 7.1			1910 / 9.1			2200 / 9.8		
Peso netto	Net weight	kg	158			185			200		

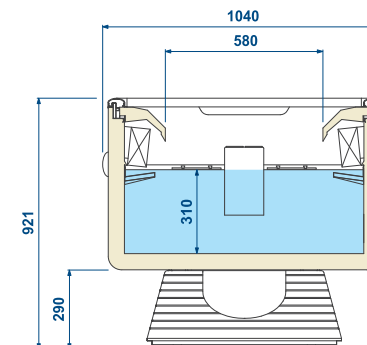

Modelli con unità condensatrici a bordo (condensazione ad aria)
 Models with condensing unit included (air cooled)